

SONY

Hi-Fi Products
Service Bulletin

Sony Service Company - Technical Services
A Division of Sony Corporation of America
Sony Drive, Park Ridge, New Jersey 07656

Model: TCD-D3

No. 203

Subject: Mechanical Alignment, After Replacing Gears

Date: August 27, 1991

Symptom:
(**)

After replacing a defective gear, the unit shows a "caution" indication.

Solution:

Mechanical alignment of load encoder, mode encoder, and cam gear "b".

- 1) Open the cassette door by applying power to the unit and pressing the eject button. Remove the cassette lid assembly by removing the two screws at the front of the assembly. Next, lift the lid off the front and set it aside. Turn the unit over, and disassemble the TCD-D3 by removing the four bottom screws and lifting the bottom plate. Then disconnect the mic DC out connector CN801, remove the lower panel bracket and the screw holding the main board down at the back of the unit. Remove the dew sensor connector CN509, and the battery connector CN505. Disconnect all flex boards, beginning with the 30 pin connector for the LCD display that runs across the unit. Then disconnect the flex boards from CN508, CN503, and CN502 on the main board. Desolder the DC-DC converter and remove all tape holding the wiring in place. Remove the control panel assy. Flip the main board up and expose the mechanism, be careful not to break any wires still soldered to the main board.

CSA-13 DAT

DISASSEMBLY

Note: Follow the disassembly procedure in the numerical order given.

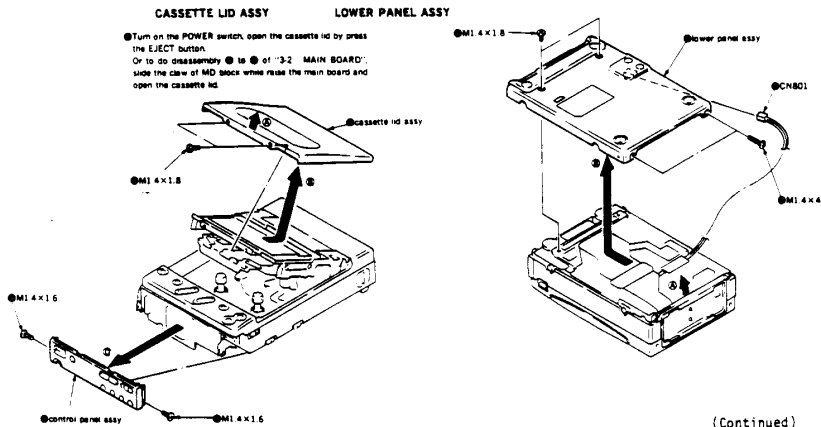

Reference: FPR M2026

PRINTED IN U.S.A.
CSA-13891-1

MAIN BOARD

Note: On assembly board, take notice of out each switches and knobs position.

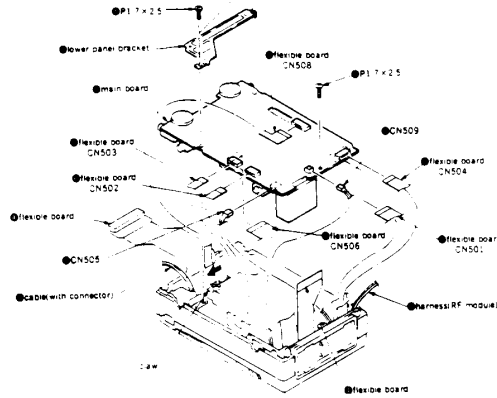

- Working from the underside of the unit, turn the capstan counter-clockwise to put the unit in a fully unloaded position. Locate the take-up/supply-reel assembly and remove the three screws that hold it in place. Take note of where the spring that "rides" on the loading gear is positioned. This information will be helpful during re-assembly. Now, using a rocking motion, lift the assembly out from the chassis and place it on the side. Locate the mode encoder and align the arrow on the outside edge to the small hole in the chassis (See diagram). Locate the load encoder and align it so the second tooth is aligned with the small hole in the chassis (See diagram).

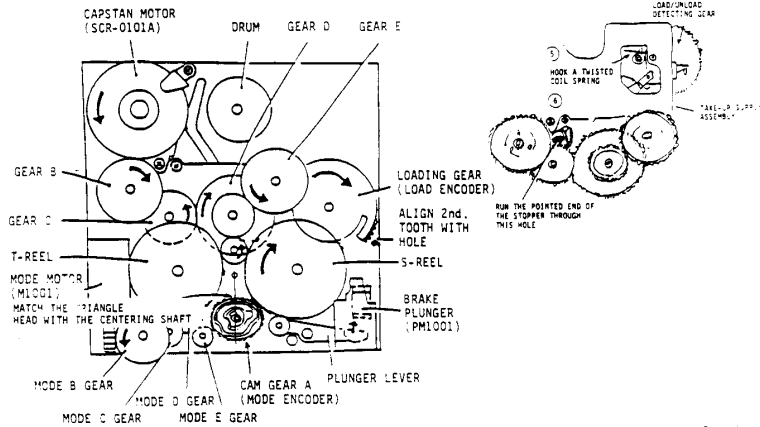

Continues

- 3) Turn the unit over, and with the cassette door open, check Cam gear B. It must be aligned with the raised lobe at approximately a 4 o'clock position.

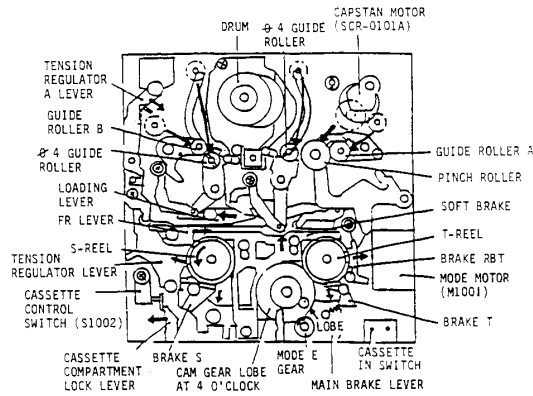

- 4) Turn the unit over, with the bottom of the unit facing up, begin to re-assemble the mechanism. Starting with the take-up/supply reel assembly and working in reverse order re-install the assembly. Be careful not to force this part back into the chassis or move any of the gears you just aligned. After placing the take-up supply reel assembly into position, make sure the spring that supplies pressure to the loading gear is in the correct position (See diagram). Turn the capstan flywheel slightly (approx. 1/8 turn) clockwise and counter-clockwise to insure that all the gear teeth are meshing correctly. Screw in the take-up/supply reel assembly.

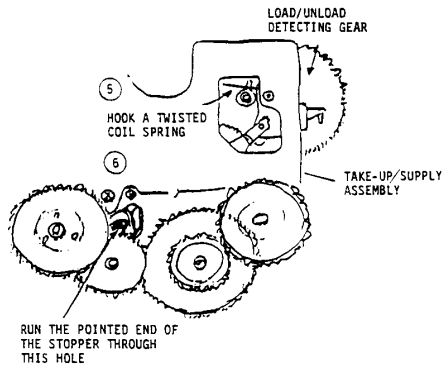

(Continued)

- 5) Lower the main board back into position over the mechanism and re-attach the flex boards into connectors. Re-assemble the lower panel bracket and rear screw holding the main board in place. Replace the dew sensor, and battery connections. Resolder the DC-DC converter. Re-attach the control panel assy.

MAIN BOARD

Note: On assembly board, take notice of out each switches and knobs position.

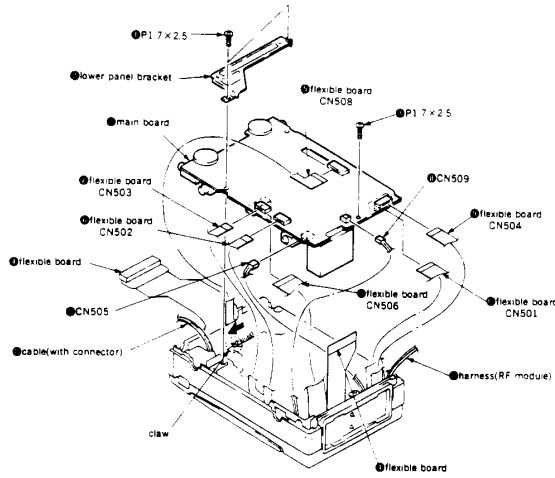

- 6) Apply power to the unit, press EJECT to open the cassette lid and insert a tape. Turn power switch ON and see if tape wraps correctly with no "caution" indication. Press PLAY and verify that the tape is playing normally. If a caution indication is seen, check all the flex board connections. If the connections appear to be good repeat steps 1 to 5. If everything is working correctly, reassemble the cassette lid assembly. Turn the unit over and reattach the bottom plate. The TCD-D3 is now mechanically aligned.

